



HOT WATER HANGING UNIT HEATER

Model: HHA50, HHA100

INSTALLATION & USER MANUAL

Please read and retain this manual for future reference.

www.hamaom.com

support@hamaom.com

(800) 918-2977

(8:00 am to 7:00 pm PST), Monday to Friday

| Contents

Safety Considerations	2
General Information	2
Standard Features	3
Installation	4
Filter Cleaning	5
Dimensions	6
Circuit Diagram	7
Specifications	7
Warranty	8

| Safety Considerations

To reduce the risk of fire, electric shock or personal injury, please observe the following.



- Installation or repair of this equipment must be performed by a qualified service agency.
- Always disconnect the power supply before making wiring connections to prevent electrical shock and equipment damage.
- Any original factory wiring that requires replacement must be replaced with wiring material having a temperature rating of at least 221°F.
- When installing, the clearance for the back of the heater should be at least 6 inches from the wall.
- Do not start the unit without the filter installed to prevent debris from being drawn in and damaging the heater.
- Be sure no obstructions block air intake or air discharge of the heater.

| General Information

Installation and service instructions in this manual apply to the HAMAOM hot water hanging unit heaters which should be installed using proper applications for their most effective function as a hanging unit heater.

HAMAOM hot water hanging unit heaters use the energy from a building's hot water source to offer efficient, whisper quiet operation, and come with a temperature control switch, sensing the temperature of the water inlet to control the fan start/off, reducing frequency of manual operations to save you time.

The fan will automatically start when the temperature of the water inlet side reaches the preset value. The fan will automatically switch off when the temperature of the water inlet side falls below the preset value. Once you have completed the installation of your unit heater, preset your target temperature, open your hot water valve, and HAMAOM heater will do the rest.

Ideal for use in living rooms, bedrooms, garages, warehouses and greenhouses.

Standard Features

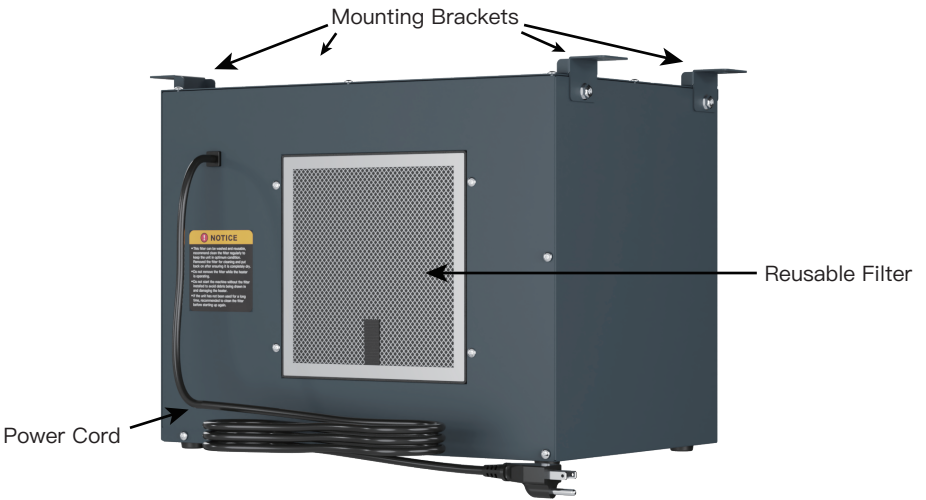
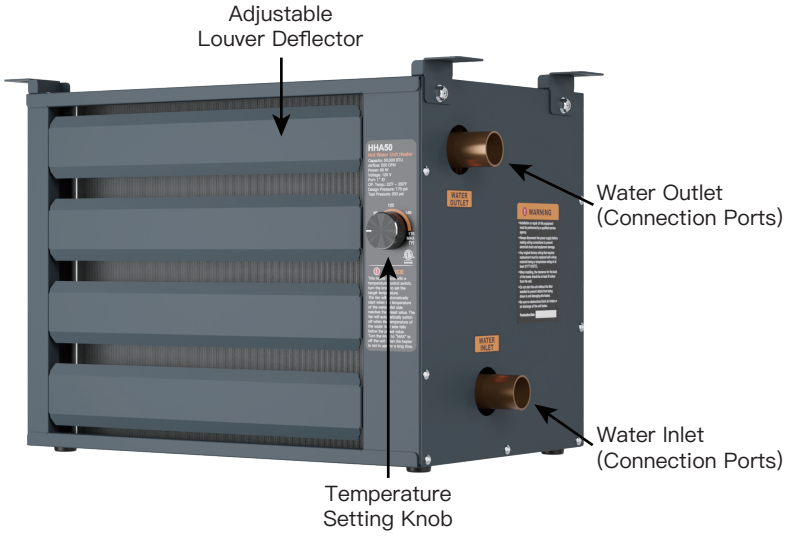

Installation

Step 1: Take out the mounting brackets(Fig.1), screws(Fig.2) and tapping screws(Fig.3) from the package.

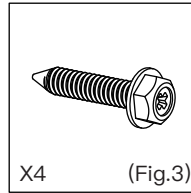
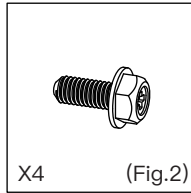
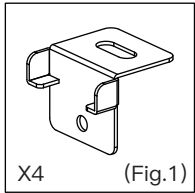

Step 2: Attach the mounting brackets to unit with screws.(Fig.4)

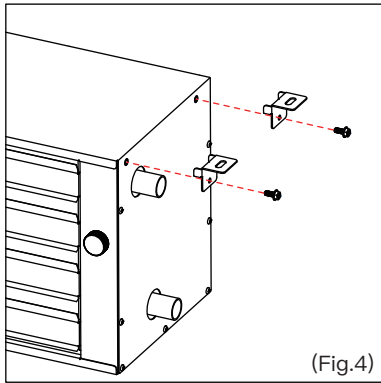

Step 3: Mount the unit to the ceiling or joists with tapping screws.(Fig.5)

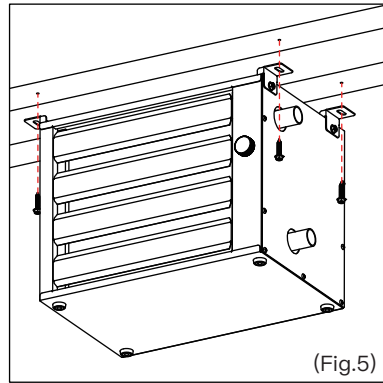

Step 4: Depending on your water pipes, choosing soldered or sweat adapters or push to fit connector to connect the unit inlet/outlet ports to your pipes.(Fig.6)

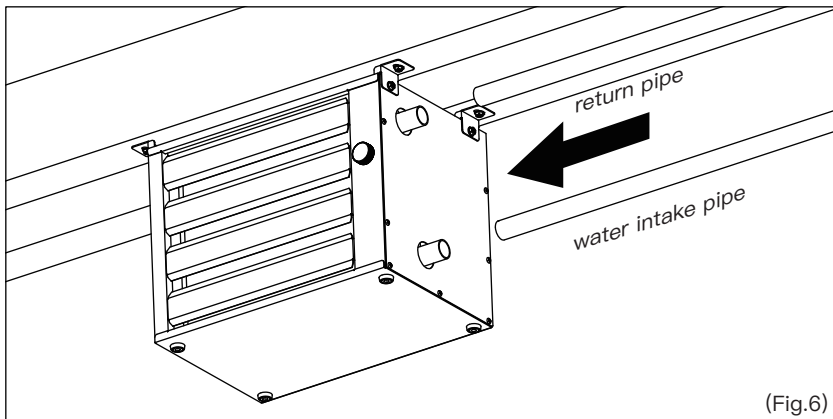

Filter Cleaning

HAMAOM hot water unit heater comes with a filter to prevent debris from being drawn in and causing damage to the interior of the unit.

This filter can be washed and reused. Please clean the filter regularly to keep the unit functioning properly.



- Do not remove the filter while the heater is operating.
- Do not start the machine without the filter properly in place prevent to prevent debris from being drawn in and damaging the heater.
- If the unit has not been used for a long time, clean the filter before turning it back on.

Step 1: Pull on the handle to remove the filter.(Fig.7)

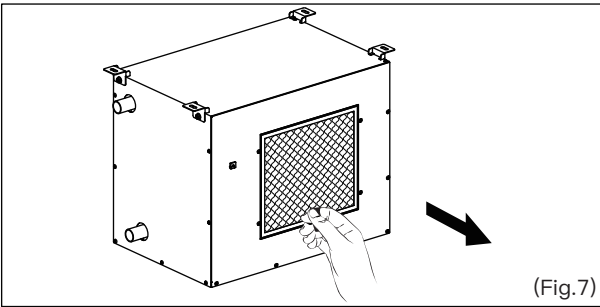

Step 2: Clean the filter and let it completely dry.

Step 3: Push the top of the filter inward to fit it back in place after ensuring it is completely dry.(Fig.8)

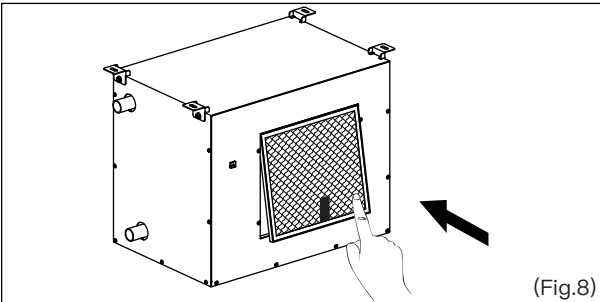

Dimensions

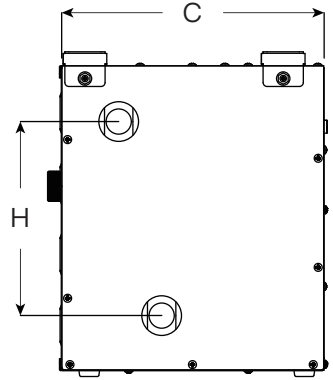
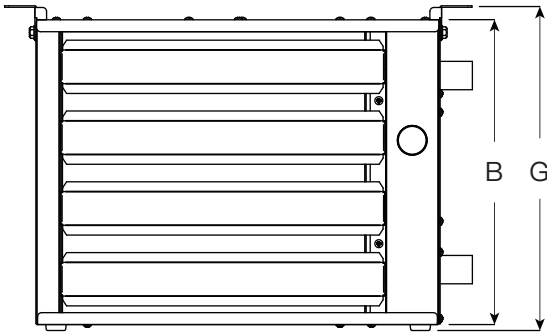
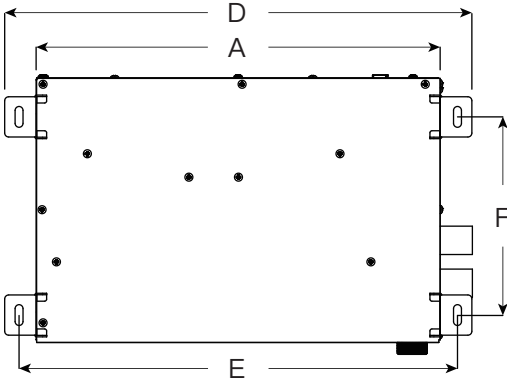

Model	A	B	C	D	E	F	G	H	Port
HHA50	16 (407)	12.1 (307)	10.5 (267)	18.6 (471)	17.4 (442)	7.9 (200)	12.9 (328)	7.71 (196)	1 (25.4)
HHA100	20.1 (509)	16.1 (409)	13.5 (344)	22.6 (573)	21.4 (544)	10.9 (277)	16.9 (429)	11.5 (292)	1 (25.4)

inch (mm)

Circuit Diagram

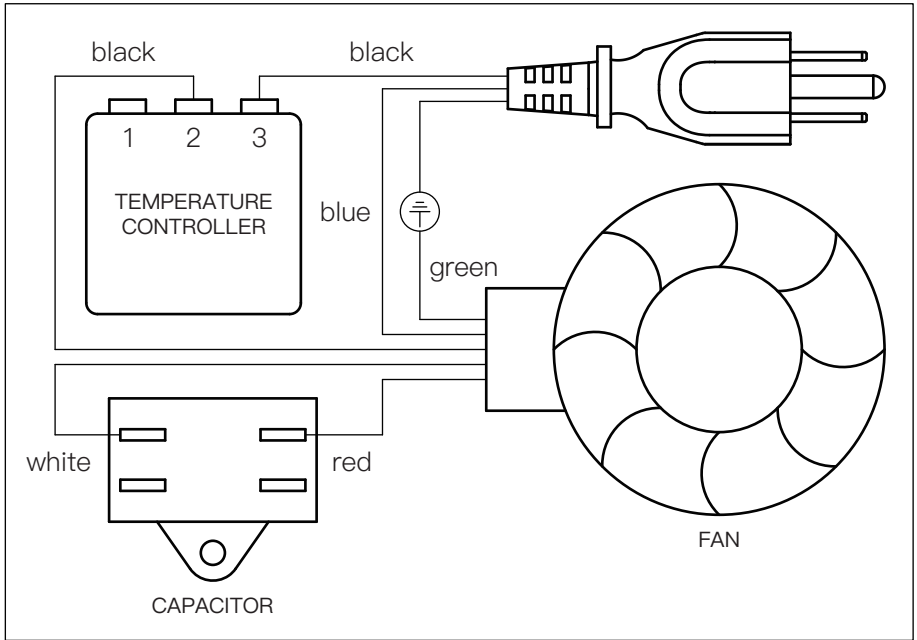

Specifications

Component	Description	Model	
		HHA50	HHA100
Heater	Capacity	50,000 BTU	100,000 BTU
	Noise	53 dBA	65 dBA
	Power Cord	10 ft	10 ft
Coil	Port	1" ID	1" ID
	Coil Size	12"x12"	16"x16"
	OP. Temp.	32°F – 350°F	32°F – 350°F
	Design Pressure	175 psi	175 psi
	Test Pressure	263 psi	263 psi
Blower	Power	60W	130W
	Voltage	120V	120V
	Airflow	500 CFM	1500 CFM

Warranty

HAMAOM ensures the product components will be free of material defects in the workmanship of its materials for 3 years following the date of initial purchase of this product by a customer. This warranty is limited to the repair or replacement of defective equipment.

If it is necessary to return a unit for service, the customer is solely responsible for proper packaging and transportation costs. Customers must initiate the warranty process by contacting HAMAOM. Do not send any component or product back to HAMAOM without a return material authorization.

This limited warranty does not apply to any part or component that is damaged in transit, been subject to misuse, corrosion, chemicals, acts of God, has not been installed, operated, or serviced according to the seller's instructions, has been operated beyond the factory rated capacity, or has been altered in any way. Routine maintenance is not covered by this warranty.

This limited warranty is void if defect(s) result from failure to have this unit installed by a qualified heating and air conditioning contractor.

HAMAOM shall not be responsible for loss of function of any product, loss of time, inconvenience, or damage to other equipment, or any other indirect or consequential damage any to property whether as a result of a breach of warranty, neglect, or otherwise.

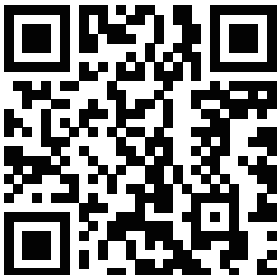

www.hamaom.com/warranty

support@hamaom.com

(800) 918-2977

(8:00 am to 7:00 pm PST), Monday to Friday

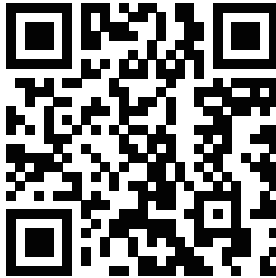

WARRANTY
QR CODE

www.hamaom.com
support@hamaom.com
(800) 918-2977
(8:00 am to 7:00 pm PST), Monday to Friday